

00

ORGANE DE BASE MOTEUR

ENGINE BASIC COMPONENT

GRUNDORGAN MOTOR

40

ORGANE MOTEUR NU

ENGINE COMPONENT

ORGAN MOTOR

202

MOTEUR M 32 S

ENGINE M32S

MOTOR M32S

IMPORTANT

Il est dans votre intérêt de conserver à leur classement les feuillets de mise à jour du catalogue, parus avant cette édition.

IMPORTANT

It is advisable to keep the pages bringing the catalogue up to date, which were printed prior to this edition, in their file.

WICHTIG

Es liegt in Ihrem Interesse, die Blätter der vor dieser Ausgabe erschienenen Nachträge zum Katalog an der Ablagestelle aufzubewahren.

camions
UNIC
FIAT

CATALOGUE RELEVÉ AU 19-10-71

Motor N° 10.816

CATALOG ACCOUNTING AS OF 19-10-71

Engine N° 10.816

KATALOGGAUSZUG ZUM 19-10-71

Motor Nr 10.816

MOTEUR M 32 SD

ENGINE M 32 SD

MOTOR M 32 SD

Bloc-cylindres, carter volant <i>Cylinder block, flywheel casing</i> <i>Zylinderblock, Schwungrad Gehäuse</i>	00	01
Culasses, couvre-culasses, culbuteurs <i>Cylinder heads, cylinder head cover, valve levers</i> <i>Zylinderkopfe, Zylinder-Haube, Ventilhebel</i>	00	02
Vilebrequin, bielles, pistons, volant <i>Crankschaft, connecting rods, pistons flywheel</i> <i>Kurbelwelle, Pleuel, Kolben, Schwungrad</i>	00	03
Distribution, arbre à cames <i>Valve gear, camshaft</i> <i>Verteilung, Nockenwelle</i>	00	04
Commande d'avance automatique et de pompe d'injection <i>Automatic advance and injection pump control</i> <i>Betätigung der automatischen Zündverstellung und der Einspritzpumpe</i>	00	05
Installation pompe d'injection et tubes <i>Installation of injection pump and tubes</i> <i>Einbau der Einspritzpumpe und Rohre</i>	00	06

00	40	202	N° DE CATALOGUE	N° DE PLANCHE
1	2	3	4	5

EDITION : 15/02/72
AUSGABE :

1	ORGANE DE BASE	BASIC COMPONENT	GRUND-ORGAN
2	ORGANE	COMPONENT	ORGAN
3	TYPE D'ORGANE	COMPONENT TYPE	ORGANTYP
4	N° ÉDITION	CATAL. EDITION NUMBER	NUMMER DER AUSGABE
5	N° PLANCHE	PLATE NUMBER	BILD Nr.
6	REPÈRE	MARKING	KENNZIFFER

7	N° PIÈCE	PART N°	TEIL Nr.
8	DÉSIGNATION	DESIGNATION	BESCHRIFTUNG
9	QUANTITÉ	QUANTITY	MENGE
10	CODE OBSERVATIONS	CODE OF OBSERV.	ANMERKUNGEN KODE
11	DÉTAILS OBSERVATIONS	DETAILS OF OBSERV.	ANMERKUNGEN BEDEUT.

Référence : 655.506
Kennzahl :

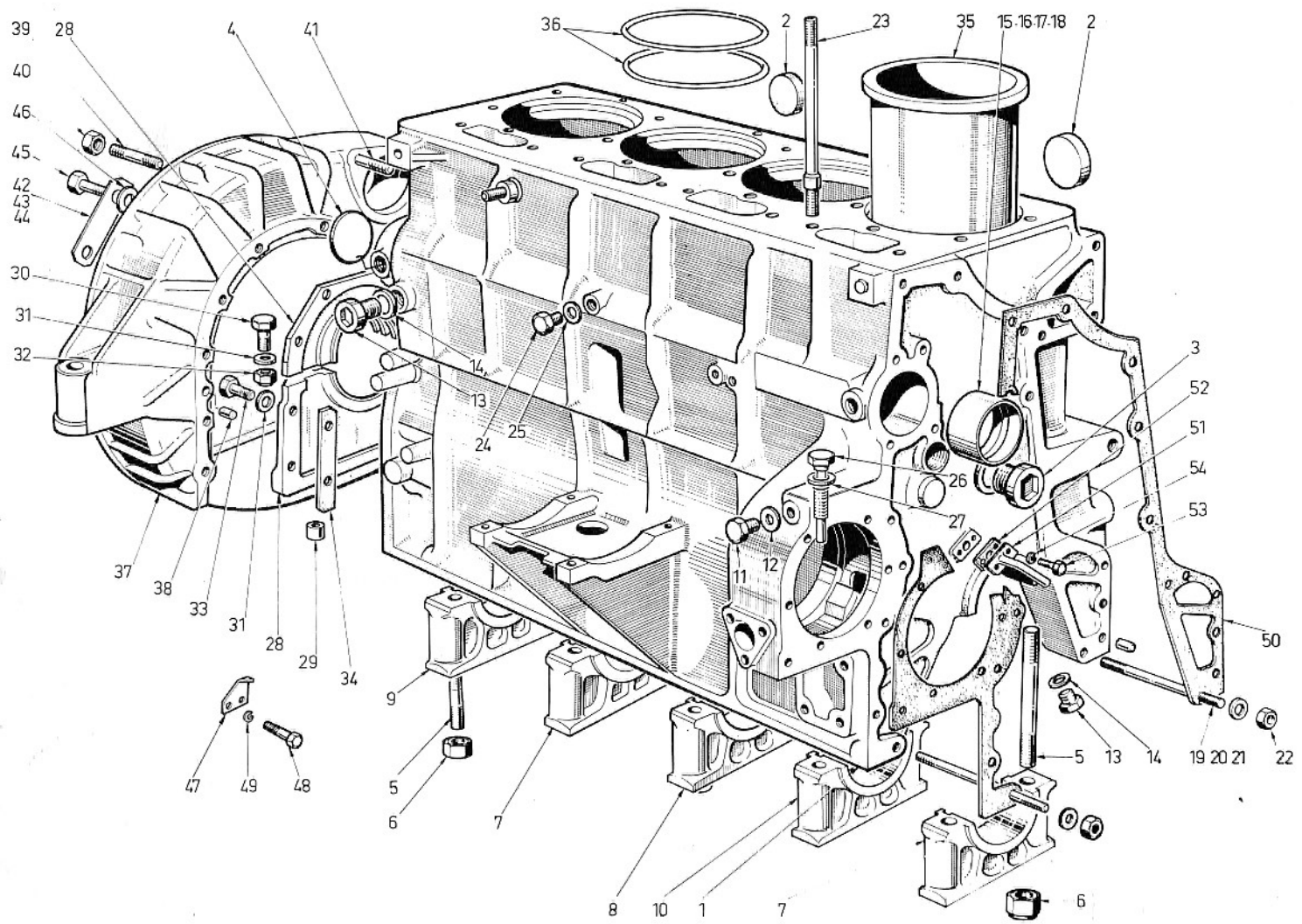

00	40	202	00	01
1	2	3	4	5

6	7	8	9	10
1	61657115	CARTER ASS	1	
2	61860103	BOUCHON	3	
3	61574796	BOUCHON	2	
4	61404003	BOUCHON	1	
5	61229500	GOUJON	10	
6	61117535	ECROU	10	
7	61210969	CHAPEAU	2	
8	61210970	CHAPEAU	1	
9	61210971	CHAPEAU	1	
10	61210972	CHAPEAU	1	
11	61835324	BOUCHON	1	
12	61073295	JOINT	1	
13	61403000	BOUCHON	2	
14	61206081	JOINT	2	
15	61224403	BAGUE 211770..	1	
16	61224403	BAGUE REPAR	1	
17	61224404	BAGUE REPAR	1	
18	61224406	BAGUE REPAR	1	
19	61520043	GOUJON LON 95	1	
20	61520044	GOUJON LON 105	1	
21	61520045	GOUJON LON 100	1	
22	61801013	ECROU	3	
23	61238412	GOUJON	24	
24	61227117	BOUCHON	1	
25	61221724	JOINT	1	

6	7	8	9	10
26	61226411	GICLEUR	1	
27	61815086	JOINT	1	
28	61274586	CCUVERCLE	1	
29	61225321	BAGUE	2	
30	61802609	VIS	2	
31	61230425	RONDELLE	10	
32	61801353	ECROU	2	
33	61802605	VIS	8	
34	61205763	JOINT	1	
35	61215563	CHEMISE	4	
36	61219676	JOINT	12	
37	61661142	CARTER	1	
38	61206044	PIED	2	
39	61520041	GOUJON	12	
40	61801012	ECROU	12	
41	61520040	GOUJON	3	
42	61229236	FREIN	2	
43	61229237	FREIN	2	
44	61229238	FREIN	1	
45	61229229	VIS	10	
46	61229230	RONDELLE	10	
47	61226337	FLECHE	1	
48	61802572	VIS	2	
49	61815223	RONDELLE	2	
50	61224154	JOINT	1	

11	12

11	12

00	40	202	00	01
1	2	3	4	5

DÉSIGNATION PLANCHE : SE RÉFÉRER AUX PAGES "SOMMAIRE"
 PLATE DESIGNATION : REFER TO FLYLEAF
 BILDBESCHRIFTUNG : SIEHE VORSATZBLÄTTER



6	7	8	9	10
51	61273297	TUBE	1	
52	61207974	JOINT	1	
53	61802575	VIS	2	
54	61225185	FREIN	2	
999	61141632	POCHETTE JOINT	1	

6	7	8	9	10

11	12

11	12

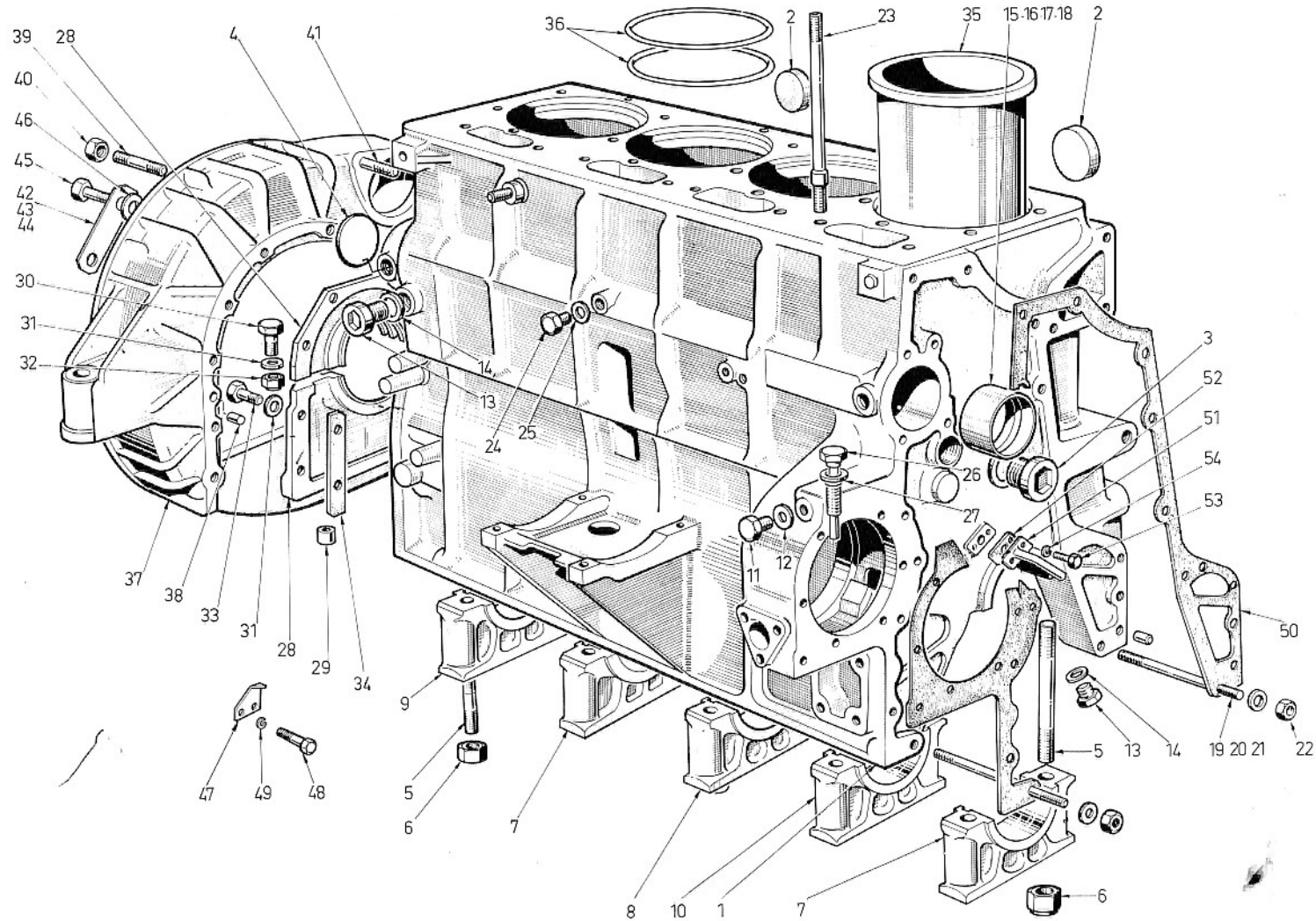

00	40	202	00	01
1	2	3	4	5

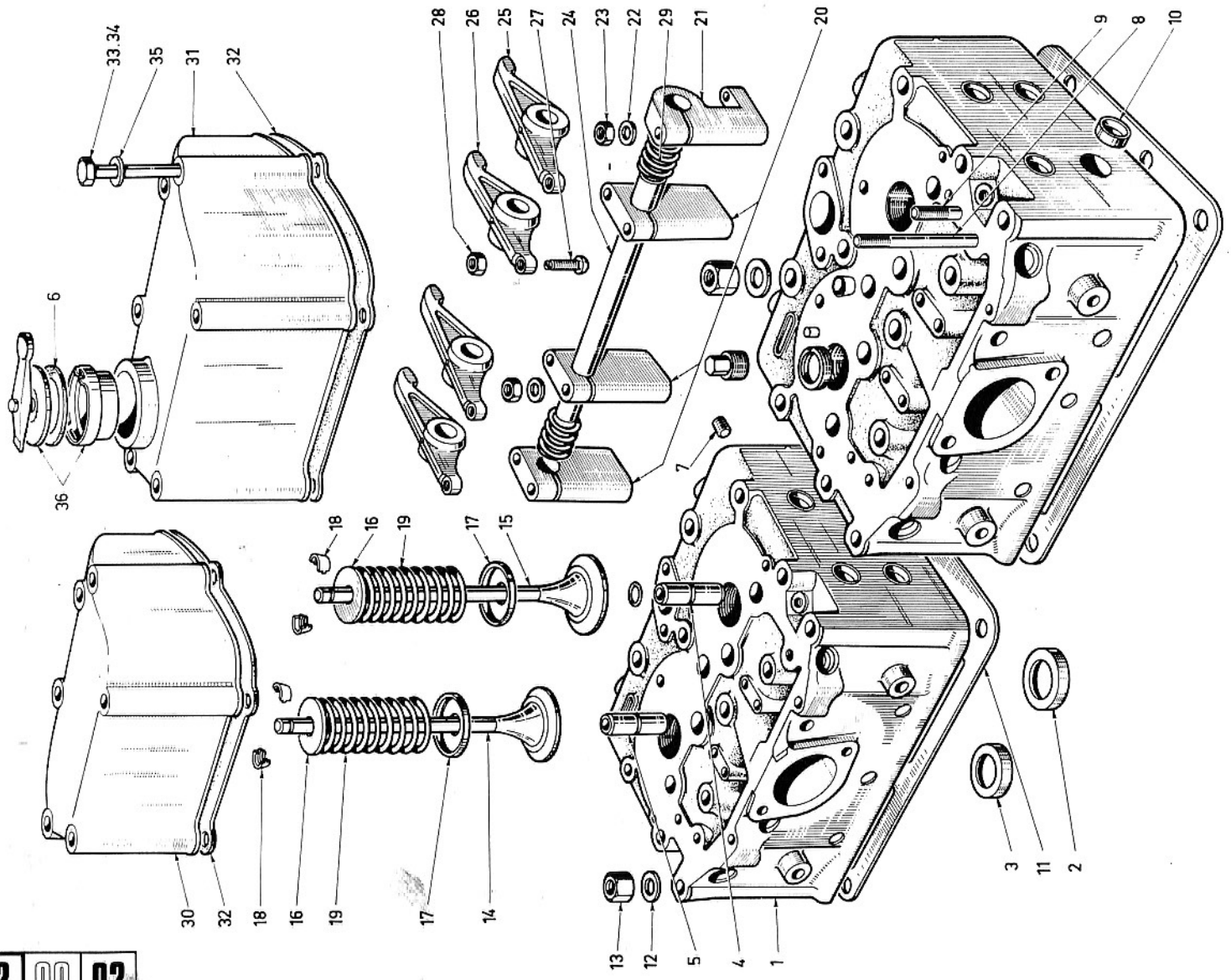

00	40	202	00	02
1	2	3	4	5

6	7	8	9	10
1	61668145	CULASSE ASS	2	
2	61227957	SIEGE ECH	4	
3	61238847	SIEGE ADM	4	
4	61224750	GUIDE ECH	4	
5	61224749	GUIDE ADM	4	
6	61815174	JOINT	1	
7	61229435	FILET	8	
8	61520038	GOUJON	14	
9	61520039	GOUJON	2	
10	61217230	BOUCHON	20	
11	61228746	JOINT	2	
12	61228026	RONDELLE	24	
13	61210208	ECROU	24	
14	61228562	SOUPAPE ADM	4	
15	61228561	SOUPAPE ECH 61584635.	4	
16	61228568	CUVETTE	8	
17	61224755	COUPELLE	8	
18	61233708	CLAVETTE 574467	16	
19	61207895	RESSORT	8	
20	61224600	SUPPORT	6	
21	61224773	SUPPORT	2	
22	61815224	RONDELLE	16	
23	61801011	ECROU	16	
24	61660498	AXE	1	
25	61224596	CULBUTEUR	4	

6	7	8	9	10
26	61224595	CULBUTEUR	4	
27	61205738	ROTULE	8	
28	61801031	ECROU	8	
29	61225601	RESSORT	4	
30	61224718	COUVRE CULASSE	1	
31	61664236	COUVRE CULASSE	1	
32	61225425	JCINT	2	
33	61802623	VIS LON 110	8	
34	61802621	VIS LCN 90	4	
35	61815004	RONDELLE	12	
36	61660281	BCUCHGN	1	

11	12

11	12

00 40 202 00 03

DÉSIGNATION PLANCHE : SE RÉFÉRER AUX PAGES "SOMMAIRE"

PLATE DESIGNATION : REFER TO FLYLEAF

BILDBESCHRIFTUNG : SIEHE VORSATZBLÄTTER



1 2 3 4 5

6	7	8	9	10
1	6165650C	VILEBREQUIN	1	
2	61205988	BOUCHON	4	
3	61204017	ROULT	1	
4	61210805	TOLE	1	
5	61850541	CIRCLIPS	1	
6	61417010	CLAVETTE	1	
7	61220268	PIGNON	1	
8	61227002	DEFLECTEUR	1	
9	61658937	VOLANT ASS	1	
10	61205776	COURONNE	1	
11	61225309	VIS	4	
12	61206165	FREIN	4	
13	61225307	ECROU	4	
14	61271550	COUSSINET <i>205078 et 079</i>	3	
15	61274503	COUSSINET 025	3	
16	61274504	COUSSINET 050	3	
17	61274505	COUSSINET 075	3	
18	61274506	COUSSINET 1	3	
19	61271551	COUSSINET <i>antérieur 205080 et 81</i>	1	
20	61274499	COUSSINET 025	1	
21	61274500	COUSSINET 050	1	
22	61274501	COUSSINET 075	1	
23	61274502	COUSSINET 1	1	
24	61271552	COUSSINET <i>PR 205078 et 83</i>	1	
25	61274507	COUSSINET 025	1	

11	12

6	7	8	9	10
26	61274508	COUSSINET 050	1	
27	61274509	COUSSINET 075	1	
28	61274510	COUSSINET 1	1	
29	61237759	DEMI FLAS	2	
30	61237760	DEMI FLAS 015	2	
31	61237761	DEMI FLAS 030	2	
32	61237762	DEMI FLAS 050	2	
33	61234701	DEMI FLAS	2	
34	61236059	DEMI FLAS 015	2	
35	61236060	DEMI FLAS 030	2	
36	61236061	DEMI FLAS 050	2	
37	61656399	BIELLE ASS	4	
38	61205778	VIS	8	
39	61212126	BAGUE <i>211.307</i>	4	
40	61205075	COUSSINET <i>213959</i>	4	
41	61209311	COUSSINET 025	4	
42	61209312	COUSSINET 050	4	
43	61209313	COUSSINET 075	4	
44	61209314	COUSSINET 1	4	
45	61234476	PISTON <i>233990</i>	4	
46	61239260	SEGMENT	4	
47	61229065	SEGMENT	8	
48	61658991	SEGMENT RACLEU	4	
49	61229211	AXE DE PISTON	4	
50	61850538	CIRCLIPS	8	

11	12

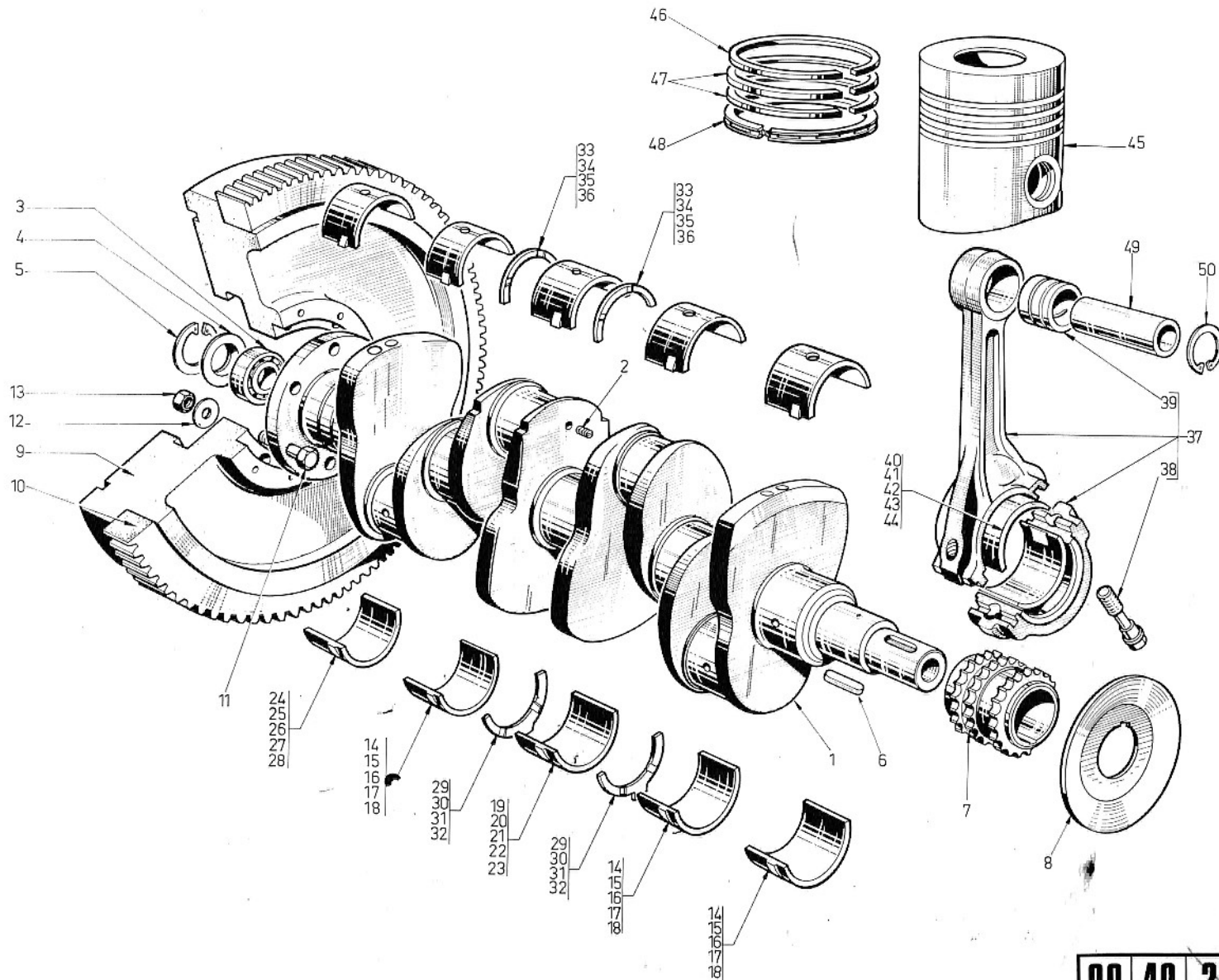

00	40	202	00	03
1	2	3	4	5

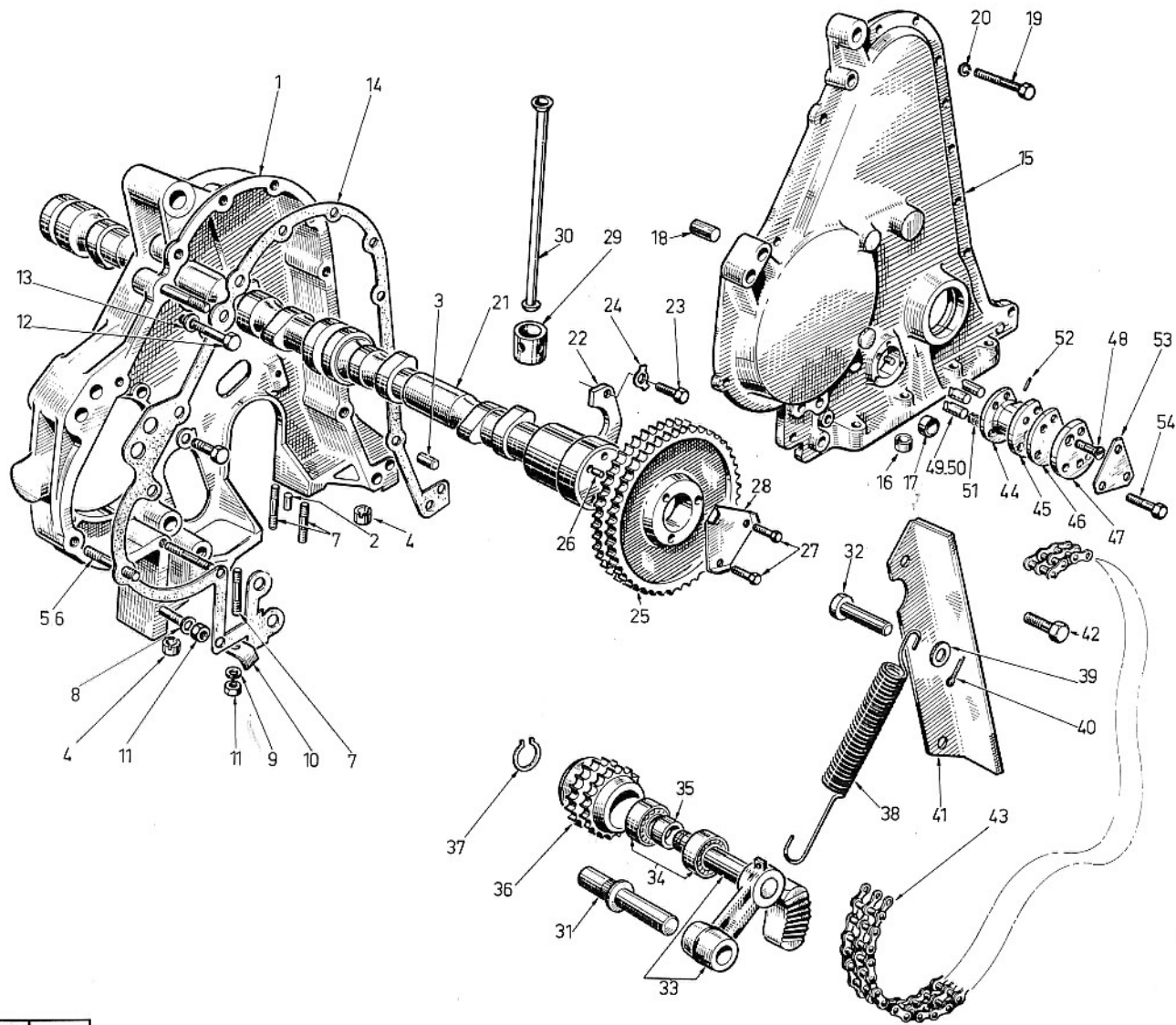

00	40	202	00	04
1	2	3	4	5

6	7	8	9	10
1	61657119	CARTER ASS	1	
2	61206045	PIED	2	
3	61205357	PIED	1	
4	61225321	BAGUE	2	
5	61417205	GOUJON D8 L 20	4	
6	61520047	GOUJON D 8 L45	1	
7	61417211	GOUJON D8 L25	4	
8	61230425	CNDUFLEX DE 8	5	
9	61815004	RONDELLE DE 8	4	
10	61205764	FREIN	2	
11	61801011	ECROU DE 8	9	
12	61417C66	VIS D 8 L20	6	
13	61230425	ONDUFLEX DE 8	6	
14	61224155	JOINT	1	
15	61656183	COUVERCLE ASS	1	
16	61225321	BAGUE	4	
17	61860103	BOUCHON	1	
18	61206702	PIED	1	
19	61802620	VIS D8 L85	6	
20	61230425	ONDUFLEX DE 8	6	
21	61239661	ARBRE A GAMES	1	
22	61229639	BUTEE	1	
23	61802603	VIS D8 L 16	2	
24	61205766	FREIN	2	
25	61205767	PIGNON	1	

6	7	8	9	10
26	61205769	PION	1	
27	61205768	VIS	3	
28	61205770	FREIN	1	
29	61228757	POUSSOIR	8	
30	61228776	TIGE	8	
31	61224539	AXE	1	
32	61215064	ATTACHE	1	
33	61659037	LEVIER ASS	1	
34	61204011	ROULT 25X47X12	2	
35	61220005	ENTRETOISE	1	
36	61217622	PIGNON	1	
37	61850015	CIRCLIPS	1	
38	61573514	RESSORT	1	
39	61815006	RONDELLE	1	
40	61819922	GOUPILLE D3X30	1	
41	61665640	PATIN	1	
42	61417077	VIS D8 L16	2	
43	61205804	CHAINE	1	
44	61226975	SUPPORT	1	
45	61220000	JOINT	1	
46	61220002	JOINT	1	
47	61220001	TGLE	1	
48	61220003	VIS	2	
49	61219155	DOIGT	2	
50	61219156	DOIGT	2	

11	12
----	----

11	12
----	----

DÉSIGNATION PLANCHE : SE RÉFÉRER AUX PAGES "SOMMAIRE"
PLATE DESIGNATION : REFER TO FLYLEAF
BILDBESCHRIFTUNG : SIEHE VORSATZBLÄTTER



6	7	8	9	10
51	61220027	RESSORT	4	
52	61219157	PIED	1	
53	61220004	FREIN	1	
54	61802577	VIS	3	

6	7	8	9	10

11	12

11	12

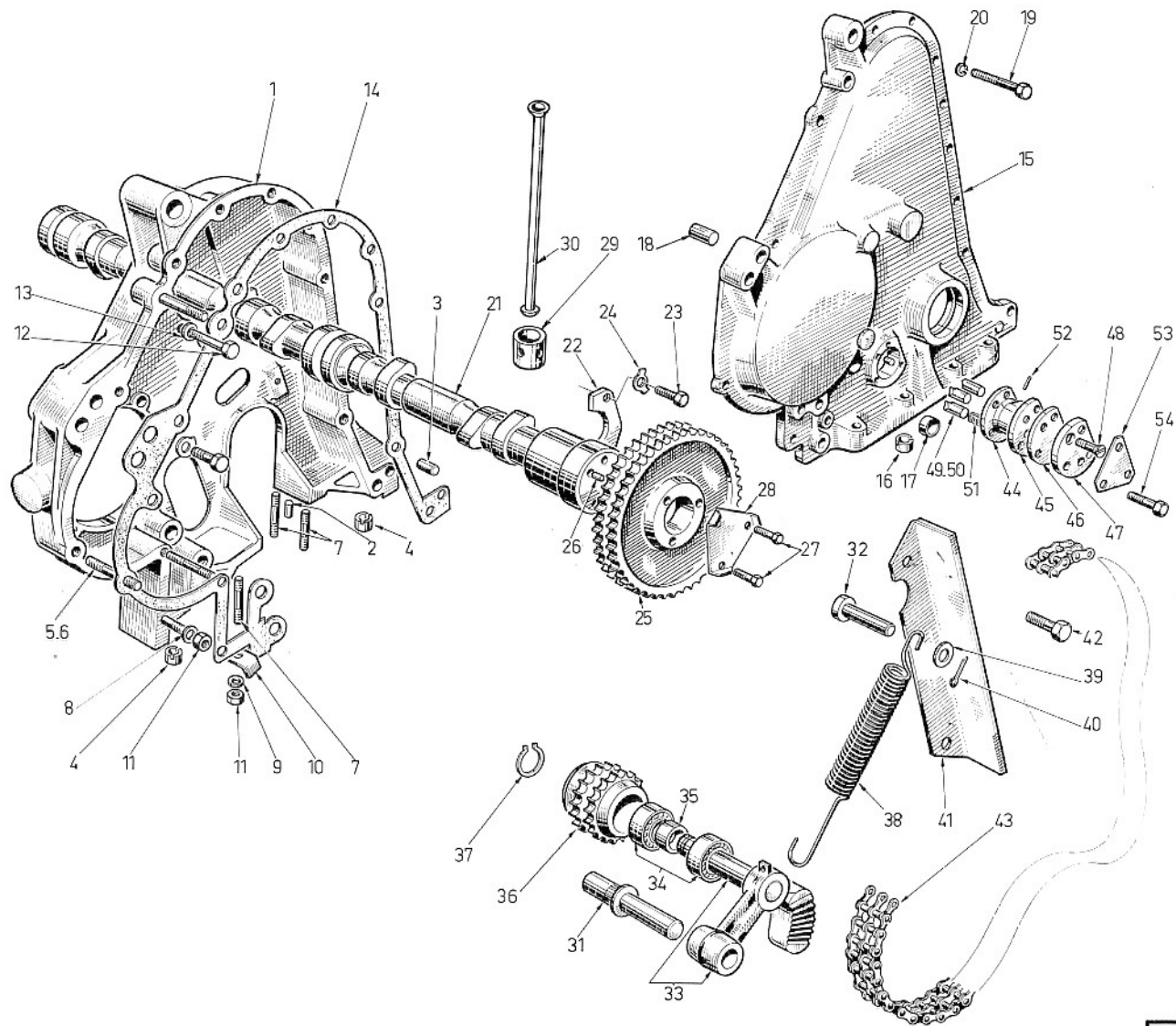

00	40	202	00	04
1	2	3	4	5

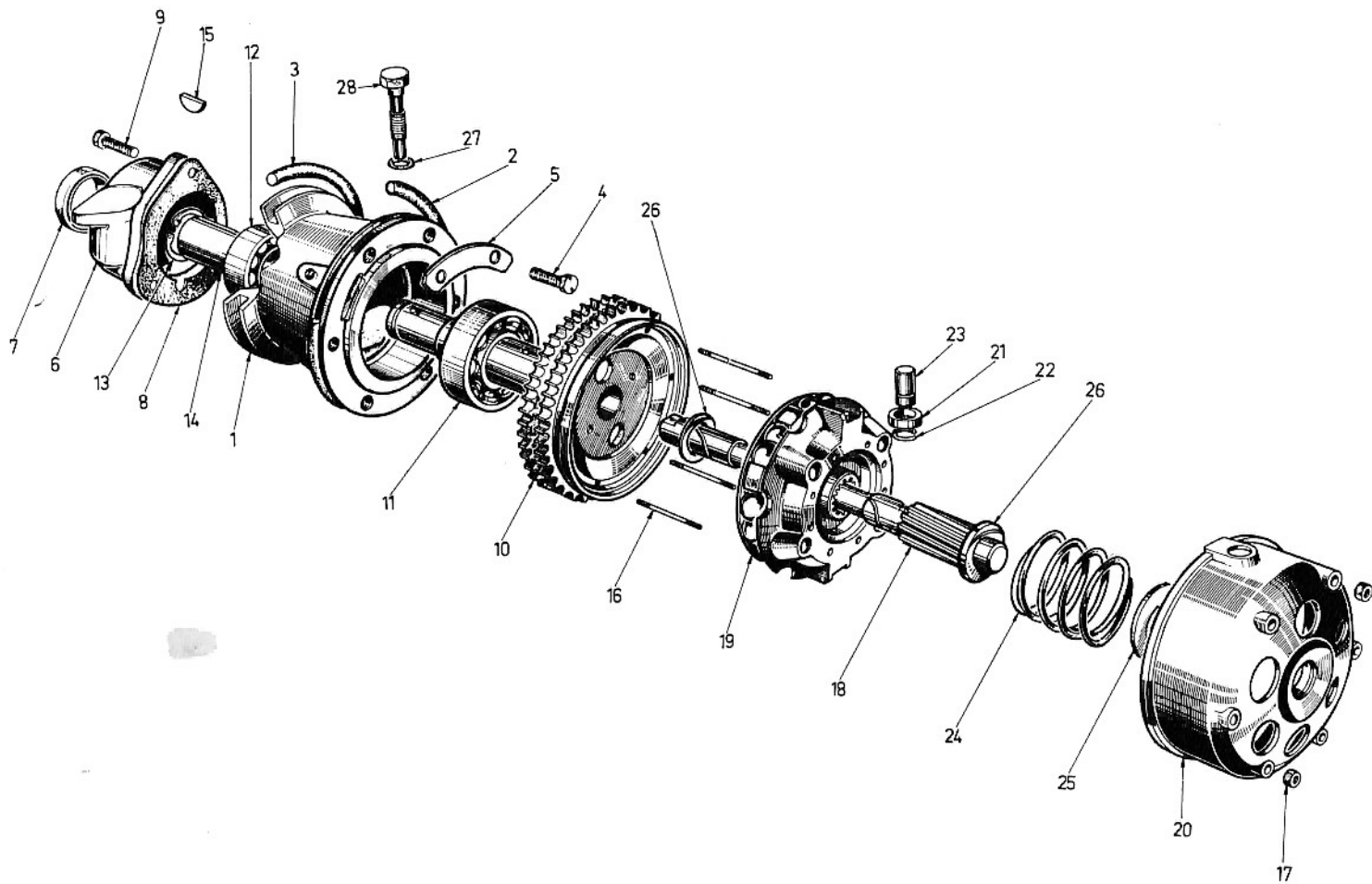

00	40	202	00	05
1	2	3	4	5

6	7	8	9	10
1	61226413	BOITIER	1	
2	61250796	JOINT	1	
3	61211752	JOINT	1	
4	61802607	VIS D8 L 25	6	
5	61211807	FREIN	3	
6	61211701	COUVERCLE	1	
7	61205746	JOINT	1	
8	61219312	JOINT	1	
9	61802573	VIS D6 L 16	3	
10	61211651	ROUE	1	
11	61204002	ROUL 35X72X17	1	
12	61204003	ROUL 30X62X16	1	
13	61850020	CIRCLIPS	1	
14	61211700	ENTRETOISE	1	
15	61844024	CLAVETTE	1	
16	61520052	GOUJONS	6	
17	61801352	SIMMONDS DE 6	6	
18	61225593	ARBRE	1	
19	61299376	PLATEAU COMPL	1	
20	61662317	BOITIER ASS	1	
21	61206210	GALET	2	
22	61206212	CIRCLIPS	2	
23	61217235	AXE	2	
24	61224936	RESSORT	1	
25	61226684	RONDELLE	1	

6	7	8	9	10
26	61225555	RONDELLE	2	
27	61815086	JCINT	1	
28	61226411	GICLEUR	1	

11	12

11	12

00	40	202	00	06
1	2	3	4	5

DÉSIGNATION PLANCHE : SE RÉFÉRER AUX PAGES "SOMMAIRE"
 PLATE DESIGNATION : REFER TO FLYLEAF
 BILDBESCHRIFTUNG : SIEHE VORSATZBLÄTTER



6	7	8	9	10
1	61670019	POMPE	1	
2	61237756	SOUPAPE	1	
3	61251960	VIS CREUSE	2	
4	61250464	RACCORD	3	
5	61208223	PREFILTRE ASS	1	
6	61105097	JOINT	1	
7	61105096	CUVE	1	
8	61105217	VIS CREUSE	1	
9	61251954	JOINT	8	
10	61251302	UNION	1	
11	61205205	JOINT	1	
12	61417080	VIS D8 L 75	4	
13	61206182	RONDELLE	4	
14	61294339	ACCOUPLLEMENT	1	
15	61251501	AMORTISSEUR	1	
16	61254067	VIS D8 L 20	2	
17	61251503	GROWER DE 8	2	
18	61251504	PLAQUETTE	2	
19	61253572	VIS D9 L 55	1	
20	61253841	ECROU DE 9	1	
21	61253842	GROWER DE 9	1	
22	61211634	FLECHE	1	
23	61802570	VIS D 6 L 10	2	
24	61815223	GROWER DE 6	2	
25	61663738	TUBE CYL 1 673750	1	

6	7	8	9	10
26	61663739	TUBE CYL 2 673751	1	
27	61663740	TUBE CYL 3 673752	1	
28	61663742	TUBE CYL 4 673753	1	
29	61216197	BAGUE	6	
30	61216196	DEMI COLLIER	6	
31	61802555	VIS D 5 L 20	3	
32	61815222	GROWER DE 5	3	
33	61801009	ECROU DE 5	3	
34	61669147	INJECTEUR BOSCH	4	
35	61667990	INJECTEUR SIGM	4	
36	61224646	ECROU	4	

11	12

11	12

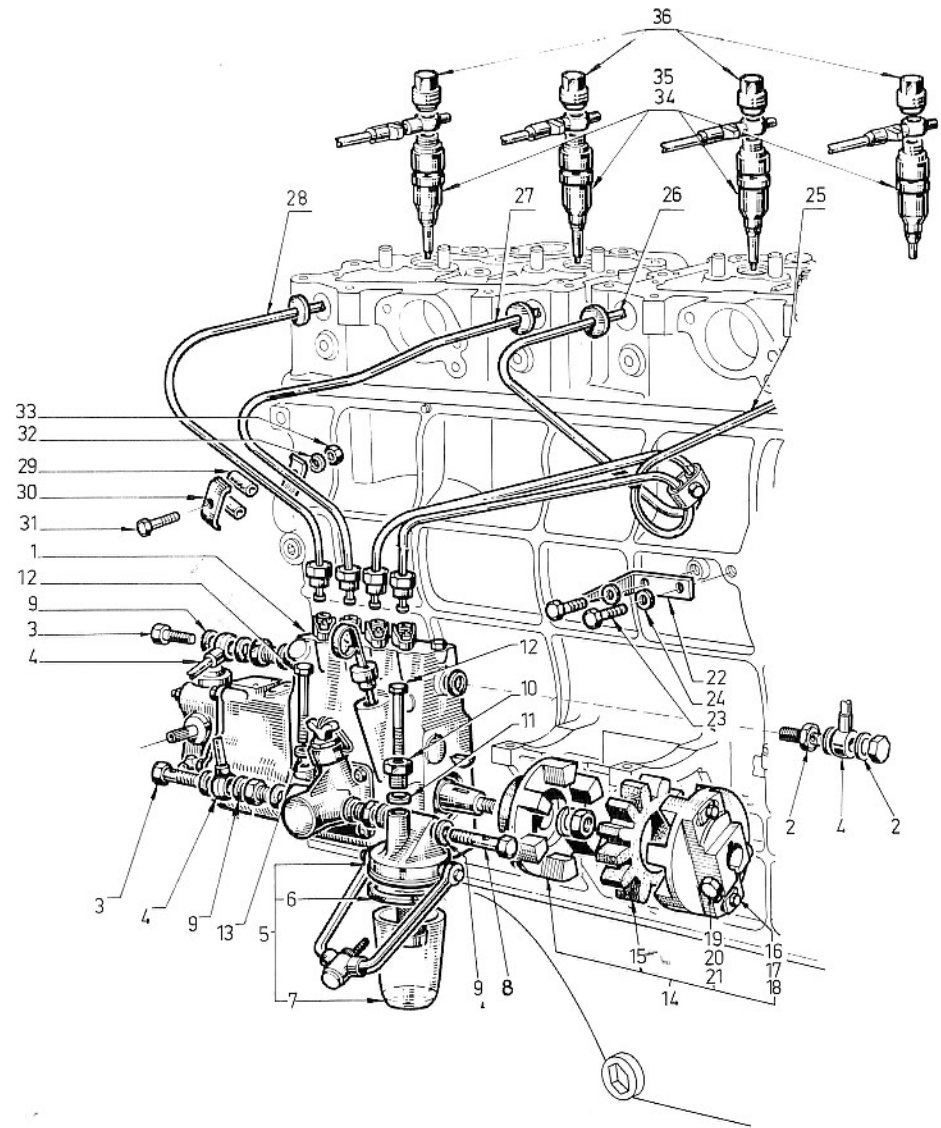

00	40	202	00	06
1	2	3	4	5